

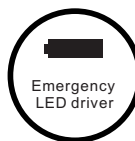

HONGYAO Lighting

Specification Sheet

- LED LINEAR STRIP -LS50 Series-

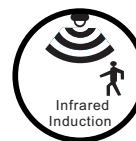
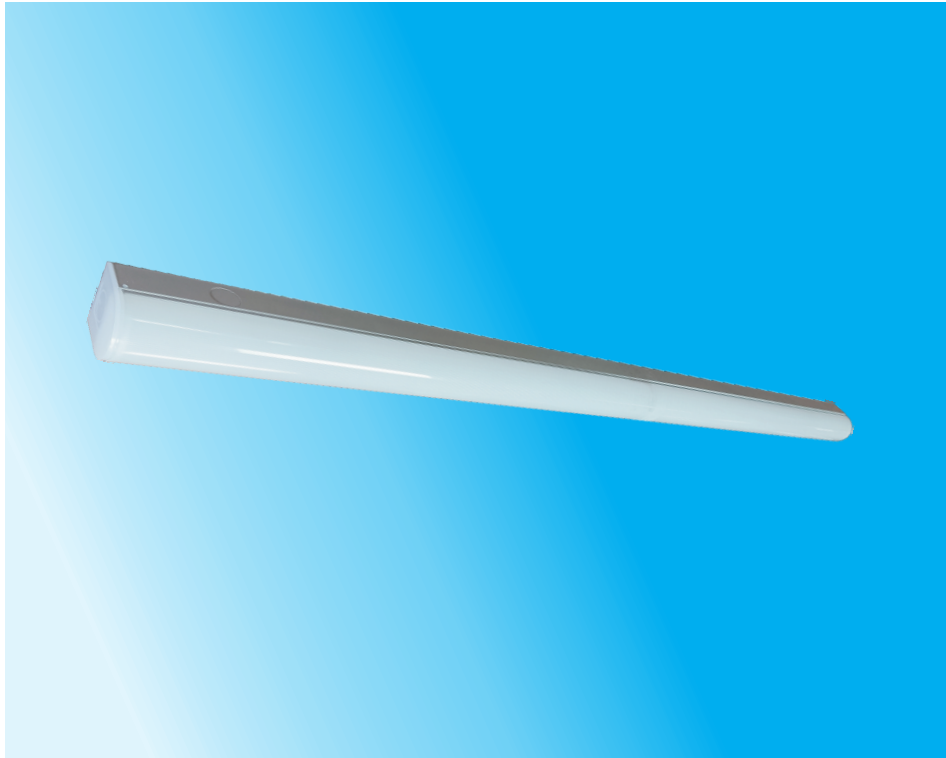

Zhejiang Hongyao Lighting Electrical Co., Ltd

No.209 Shennan Rd. Da Yang Jie Dao, Linhai City. Zhejiang China 317000 www.chongyao.com
Trading@chongyao.com Tel: +86 576-85381918 Fax:+86 576-85381913

SPECIFICATIONS

FEATURE

- Featuring tunable White Color Temperature: 3000K,4000K and 5000K
- Adjustable Wattage to meet different customer demand
- 0-10V Dimmable
- Body: Aluminum Heatsink for Efficient Heat Dissipation
- Diffusers are extruded from impact modified acrylic for increased durability
- High efficiency: 130lm/w, DLC premium listed
- Available in 2FT & 4FT
- For single or continuous run row mounting
- Linkable: with wire harness connection kit included for connecting power between fixtures
- Surface or suspension mount option
- WARRANTY--5-year limited warranty



•OPTION

- Emergency Back-up
- Motion Sensor (On/Off or Bi-Level)

APPLICATION

- shopping mall,study,offices, schools, showrooms, airports, retail, locations, and healthcare facilities

Specifications		
Model No.	HY -2FT-LS50-18W-30K/40K/50K	HY -4FT-LS50-36W-30K/40K/50K
Power:	18W	36W
Size:	2ft	4ft
Input Voltage:	120-277 VAC	
Dimming	0-10V Dimmable	
Lumens	2340LM	4680LM
Protection Rating	IP20 (For Indoor Use Only)	
Power Factor:	>0.9	
Beam Angle	120°	
CCT:	3000K/4000K/5000K	
CRI:	>80	
Working Life:	Lumen Maintenance over 70% @ 50,000+ Hours	
Oper. Temperature	-13°F ~+113°F / -25°C ~+45°C	
Certification	DLC Premium / ETL	

Zhejiang Hongyao Lighting Electrical Co., Ltd

No.209 Shennan Rd. Da Yang Jie Dao, Linhai City. Zhejiang China 317000 www.chongyao.com
 Trading@chongyao.com Tel: +86 576-85381918 Fax:+86 576-85381913

PRODUCT DIMENSIONS

4ft Front View

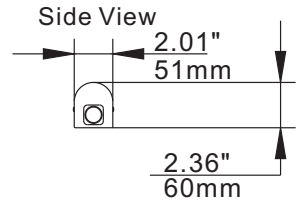
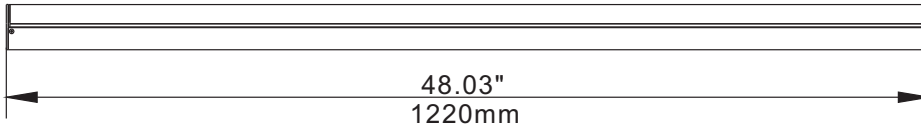

2ft Front View

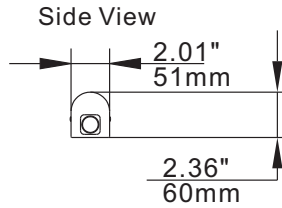
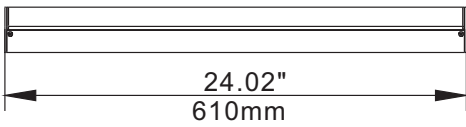

PHOTOMETRIC REPORT

4ft LED LINEAR LIGHT

LUMINOUS INTENSITY DISTRIBUTION DIAGRAM

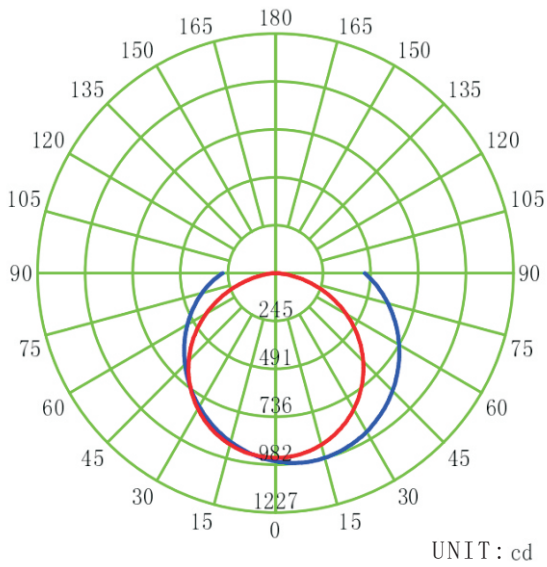

— C0-C180 — C90-C270

VERTICAL EQUILUMINOUS CURVE

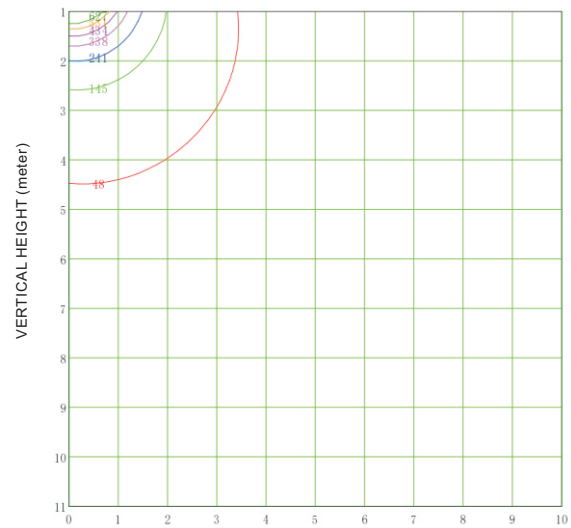

HORIZONTAL DISTANCE (meter)

MINIMUM ALTITUDE 1.0 M
MAXIMUM ALTITUDE 11.0 M
MAXIMUM ILLUMINATION 982 lx

- (5%): 48.2 lx
- (15%): 144.7 lx
- (25%): 241.1 lx
- (35%): 337.6 lx
- (45%): 434.1 lx
- (55%): 530.5 lx
- (65%): 627.0 lx



ORDERING GUIDE

Package Information		
Model No.	HY -2FT-LS50-18W-30K/40K/50K	HY -4FT-LS50-36W-30K/40K/50K
Size	2ft	4ft
Qty/Pack	12PCS	
Package Size	665X255X218mm 26.2"X10"X8.6"	1275X255X218mm 50.2"X10"X8.6"
Package Weight	8.6 kg/19 lbs	15.6 kg/34.4 lbs
Package CBM	0.036967	0.070877
40GP Capacity	~18820 PCS	~9810 PCS
40HQ Capacity	~22070 PCS	~11500 PCS
45HQ Capacity	~25310 PCS	~13200 PCS

ORDERING CODE DEFINITION

Company Code	Size	Product	Watt	XXK
HY	2ft 4ft	LS50: LED Linear light (50 Series) (CCT Tunable and Dimmable)	2ft:18W 4ft:36W	30K: 3000K 40K: 4000K 50K: 5000K CCT Selectable

WARNING

- This product must be installed in accordance with the applicable installation code by a person familiar with the construction and operation of the product and hazards involved
- Risk of fire or electric shock. LED lamp installation requires knowledge of luminaries electrical systems. If not qualified, do not attempt installation. Contact a qualified electrician.
- Use in damp location.
- Small noises when shaking does not affect the quality.



Accessories bag includes:

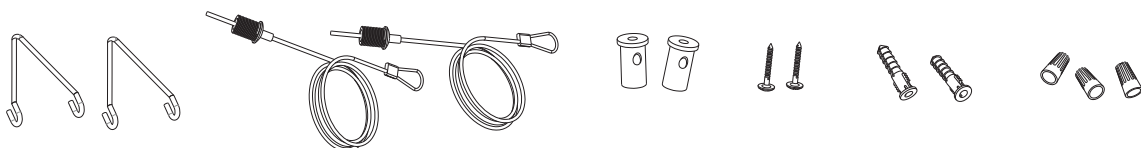

Zhejiang Hongyao Lighting Electrical Co., Ltd

No.209 Shennan Rd. Da Yang Jie Dao, Linhai City. Zhejiang China 317000 www.chongyao.com
Trading@chongyao.com Tel: +86 576-85381918 Fax:+86 576-85381913

INSTALLATION INSTRUCTION

WARNING:

1. Switch off before installation.
2. Switch on only after complete installation and examination of the circuit.

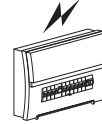
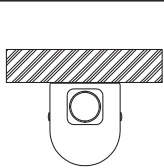

**Turn off
Power Supply**

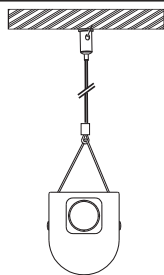
Surface Mounting

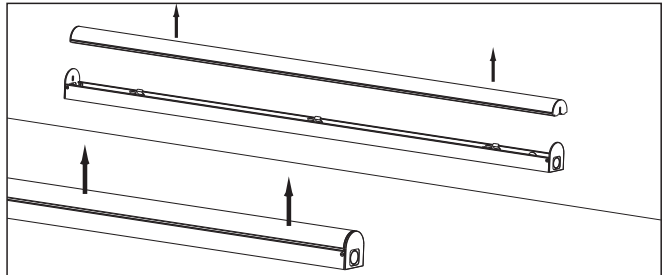

Suspension Mounting

- 1. Selecting an Installation Mode**



- 2. Remove the lampshade with force in the direction indicated by the arrow**

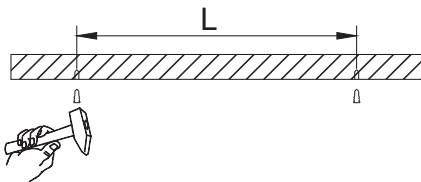

TYPE	L
HY -2FT-LS50-2W3CCT	535mm (21.06")
HY -4FT-LS50-2W3CCT	1145mm (45.08")

- 3. Drill holes in the ceiling according to the table dimensions and knock in Flanged Wall Anchor**

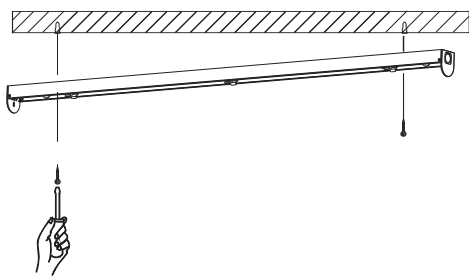
Surface Mounting

- 4. Screw the bottom case of the lamp to the ceiling**

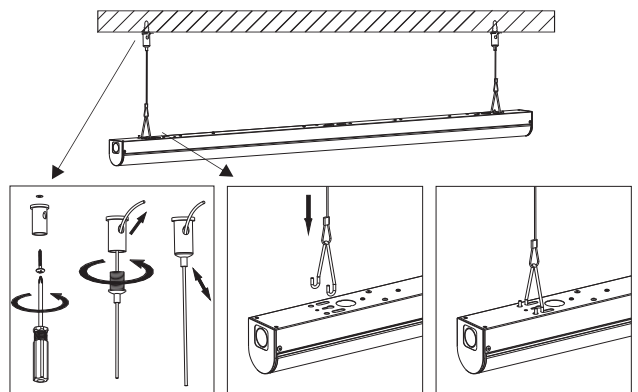
Suspension Mounting

- 5. As shown in the picture, first fix the wire lock on the ceiling, and then hang the hook at the other end on the light fixture**

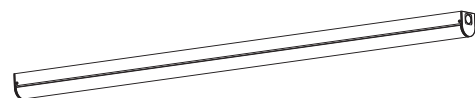
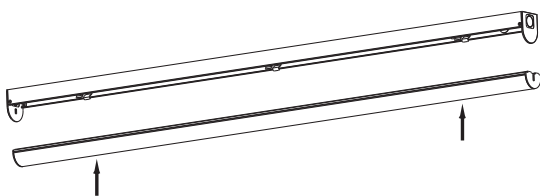

- 4. Reinstall the lampshade**

1 Adjustable CCT and Adjustable Watt

HY -2FT-LS50-2W3CCT

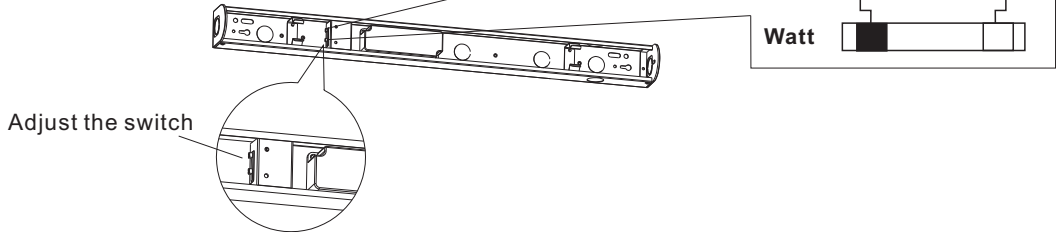

HY -4FT-LS50-2W3CCT

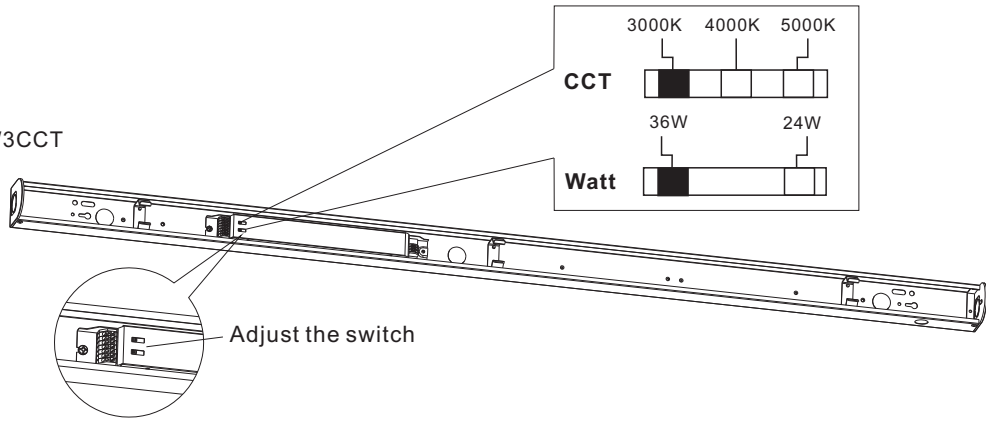

2 Wiring Guide

